



MBCA Memphis Section Newsletter - May/June 2024

# River City Star

## President's Message:

by Mike McHann



We all want to express our gratitude to Bill Sudekum for his support and contributions to our local group over the past 20 years. Bill was club Secretary for 5 years, then served as President for 8 years. He has been in constant attendance at every meeting, every event, including many of the National Events, and his leadership as President has guided us tirelessly over the decade. But Bill is now ready to step back a little bit. At our Board Member Elections last month, I was elected President, Bill was elected Vice-President and Linda Pludra was elected Secretary. Knowing I have some big shoes to fill, I hope to live up to the standards that Bill has taught us to expect from our club President and am grateful to have him to rely on as VP.

There is good news to report about the National Club. In an effort to become more efficient and effective, the National Club has relocated to a much smaller facility in Colorado and reduced Support Staff to 2 people, available by phone Tuesday thru Thursday. The old cumbersome database system has been replaced by an automated Customer Relationship Management (CRM) system that helps manage customer data, and we're already seeing the positive effects on local membership numbers.

We're having a good year with excellent attendance at events and dinners. Our monthly Cars & Carbs is growing in attendance. Last month's Art & Speed event with lunch was a tremendous success with about 30 attendees. And our recent dinner at Salsa Mexican Restaurant was the usual success with 14 members present.

**Take a look at our upcoming events and make plans to attend!**

## The 2024 MBCA-Memphis Calendar of Events

Our events include delicious dinners, fun drives and demonstrations on how to fix your car. Regardless of your interests and preferences, you will have many different events to choose from.

All members are invited to suggest additions to our calendar, whether it is regarding a dinner location, a day drive or special event. Just let any of our board members know; their contact information is listed below.

You will be provided with complete information about each event prior to the date, or, go to [memphis.mbca.org](http://memphis.mbca.org).

Date	Event	Location
May 18	Annual Car Show	Mercedes Benz, Memphis
June 1	Cars & Carbs	Panera Bread, Germantown
June 15	Quarterly Dinner, Marciano Restaurant	780 E. Brookhaven Circle
July 6	Cars & Carbs	Panera Bread, Germantown
July 13	Marshall's Steak House	2379 Highway 178, Holly Springs, MS
August 3	Cars & Carbs	Panera Bread, Germantown
August 17	Tour, Edge Motor Museum	645 Marshall Ave., Memphis Dinner, TBD
Sept. 7	Cars & Carbs	Panera Bread, Germantown

<b>Date</b>	<b>Event</b>	<b>Location</b>
Sept. 14	Carrabba's Italian Grill	4600 Merchants Park Circle S Collierville
Sept. 28	Memphis Eurofest	Memphis
Oct. 5	Cars & Carbs	Panera Bread, Germantown
Oct. 4-5	Eurofest (MS Section)	Ridgeland, MS
Oct. 19	Safari Park, lunch TBD	Como, MS
Nov. 2	Cars & Carbs	Panera Bread, Germantown
Dec. 7	Cars & Carbs	Panera Bread, Germantown
Dec. 7	Germantown Holiday Parade	Germantown, TN
Dec. 14	Holiday Party	TBD

## **A VISIT TO A LOCAL AUTOMOTIVE BOUTIQUE – WITH A NATIONAL REPUTATION**

*Add in several Mercedes with a Memphis Section connection plus a private luncheon at Highlander Pub and it all made for a great outing.*

On March 16<sup>th</sup> almost two dozen Section members, friends, and family had a chance for a guided tour of the unique facilities of Art & Speed Classic Car Gallery in Collierville, a consignment seller of unusual, sometimes rare, but always interesting collector cars of all makes and ages. Art & Speed works largely under the radar when it comes to local sales but provides national exposure (and sometime an international outlet) for cars you won't see on the lots of the national or locally owned traders here in town. Our host was A&S owner, Kevin Caffman who told the story of A&S and let us all wander around the attractive facilities and view the cars on consignment as well as the many cars being stored at A&S by local collectors or owners. A look at the large shop facilities and the vehicles "in progress" was an extra treat. Mechanical work, upholstery, and painting facilities are also in A&S's range of abilities. View all the inventory at [www.artandspeed.com](http://www.artandspeed.com).

Of special interest to our Section were several of the Mercedes-Benz cars from the collection of the late Rolf Pludra of Germantown, a long-time member of the Memphis Section. Rolf's wife Linda has placed nine of the cars with A&S on consignment, including several SL's and his very rare MB 600 limousine.

Following the visit to Art & Speed many of the members moved on to Collierville Square for the rare opportunity to have lunch at the Highlander Pub, always a popular Collierville eatery.



# Cars of Art & Speed



## **MBCA Memphis Officers:**

Section President: Mike McHann  
[Mike.mchann@eccotek.com](mailto:Mike.mchann@eccotek.com)  
901-299-6341

Section Secretary: Linda Pludra  
[pludra1945@msn.com](mailto:pludra1945@msn.com)  
901-827-4980

Section Treasurer: Lynn Jones  
[JL.Jones11@outlook.com](mailto:JL.Jones11@outlook.com)  
901-853-0846

Vice President Bill Sudekum  
[sudekumwa@msn.com](mailto:sudekumwa@msn.com)  
901-299-0653

Section VP/Membership Michael McHann  
[Mike.mchann@eccotek.com](mailto:Mike.mchann@eccotek.com)  
901-299-6341

Section Newsletter Suzanne Cunningham  
[suzflay@aol.com](mailto:suzflay@aol.com)  
901-828-5182

Regional Director Ken Koehler  
[skkoehler@att.net](mailto:skkoehler@att.net)  
317-699-2072

## A SUMMER EVENING DRIVE TO HOLLY SPRINGS AND DINNER – MARK YOUR CALENDAR

The Memphis Section MBCA is planning dinner at Marshall Steakhouse in Holly Springs on Saturday evening, July 23<sup>rd</sup>. Mark your calendar for a late afternoon drive down Highway 78 (Interstate Eye 22) and dinner at one of north Mississippi's best steakhouses. Unique décor, friendly people, separate checks, full bar. Dinner at 5:45 PM. Address of Marshall Steakhouse is 2379 Hwy. 178 West, Holly Springs, MS 38635. There will be more information in the next Newsletter as well as an Evite prior to the event.



### Memphis Membership Matters

Mike McHann (Membership Chairman)

We're very excited to welcome our newest members Mark Piper, Robert Benning, John Miller, Jr.' Mike and Julie Waker, and Shari Field-Goldberg. This brings our current membership to 82, an increase of 12 members so far this year! Remember to promote the club to your Mercedes friends, especially the many benefits which include:

1. 10 - 15% discount on parts & labor at Mercedes of Memphis, Mercedes of Collierville and Smith Imports.
2. Membership in the national club with national events, car shows and car raffles.
3. Bi-Monthly STAR magazine
4. Local club dinners, parades, car shows, etc.
5. Local newsletter

6. Technical help for your Mercedes from local club members.



I'm very encouraged about the changes coming from the National Club which promise to promote our local club membership. Until now, we depended on the STAR Magazine to communicate with our Mercedes community, but now we're switching to a web-based system to communicate online... moving from printed media to digital media. I'm already seeing the benefits of the new system with increased membership the past couple of months.

Each of us needs to login to the new website.

- <https://www.mbca.org/>
- Enter your email address and assign a new password
- A profile page will come up for you to enter your info
- If you have problems, contact me [mike@eccotek.com](mailto:mike@eccotek.com) and I'll help you get on there.

I'd appreciate your feedback regarding your experience with the

new website.

And finally, I need your old copies of the Star for our Dealer Displays. To donate, let me know and I'll come by and pick them up.

**Mike McHann**

**Membership Chairman**

**901-299-6341**

# Technical Tips and Tricks (TTT)

by Mike McHann

## Radiator Fan Clutch Replacement Gone Wrong!

Most Mercedes indicate a running temperature of 85 degrees Celsius. Last summer I noticed my 93 300CE Cabriolet was running at 90 Degrees Celsius and, having owned five of this model, I was familiar with the problem and knew the radiator fan clutch needed replacement.

The Radiator Fan Clutch, used on most models from the 80's into the 2000 model years, allows the fan to increase in rpm to a point when it will slip to limit the fan speed and provide optimal cooling. These are easy to test. With the engine at idle, insert a rolled-up magazine into the fan blades. If the fan stops turning, the clutch has failed. If you are unable to stop the fan, the clutch is still good. (Caution - don't cut your fingers off)

This is usually one of the easier maintenance tasks, with only one bolt mounting the fan to the engine output shaft.

Removing the radiator cowl, I had good access to the single mounting screw. However, what started as a somewhat simple task turned out to be much more complicated. I noticed the Belt tensioner was frozen and not releasing the belt. The tensioner uses a rubber bushing to maintain belt tension. The rubber bushing had hardened from the heat of the engine and 30 years of aging. Again not a complicated task, by removing three pulleys, the belt, mounting bracket and center bolt holding the tensioner, the tensioner and shock will easily pull straight out.

At this point in the process things got worse, the center bolt was difficult to remove and I found the screw threads damaged. I had to obtain a replacement screw from the dealer.

Removing the bolt also damaged the mounting block threads. Using a thread tap, I reformed the threads by running the tap in three times and used compressed air to clean the threaded hole of debris. Finally, everything worked out and I was able to install the new tensioner and mount the new fan clutch. This was a good time to replace the serpentine belt with a new OE part from Mercedes. Once the job was complete, the car's running temperature was back to normal. Whew! What was supposed to take 2 hours turned into a 2-day job.

I appreciate these somewhat challenging tasks. I am restoring the Cabriolet to show-room condition and the work helps achieve my goal of 100% restored. For this model year, only 700 units were produced for worldwide distribution. .

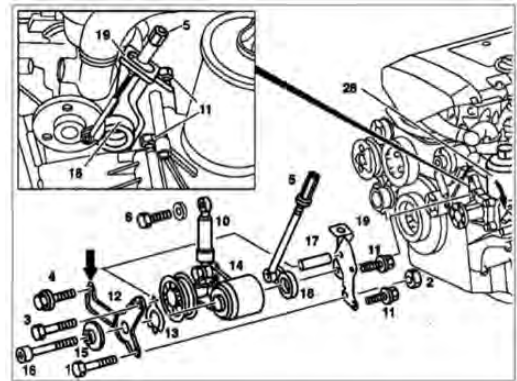

# Mercedes-AMG Petronas F-1

by Bill Sudekum, Vice President

With six F-1 races completed in the 2024 season, Mercedes-AMG still finds itself battling gremlins in their W15 cars. With the completion of the Chinese F-1 in which George Russell came in 6<sup>th</sup> and Lewis Hamilton 9<sup>th</sup>, our drivers find themselves in 6<sup>th</sup> (Russell) and 9<sup>th</sup> (Hamilton) overall. In the Constructors Standings, Mercedes is currently 4<sup>th</sup>, behind Red Bull, Ferrari, and McLaren. Toto Wolff, Team Principle, still has faith in the team and in Hamilton (primary driver), to get things right. We'll have to see what improvements they bring to Miami.

With Lewis going to Ferraril for the 2025 season, the rumor mill is still working overtime with who will fill his spot. The latest is that Max Verstappen, current F-1 leader who drives for Red Bull, wants over \$260m USD a year to drive for Mercedes, over twice his current salary. Standby for more on that item.

The next two races are: Emilia Romagna (ITA) on May 3, and Monaco (MCO) on May 26. Check your television provider for the exact channel and times.



## I Saved \$100 On My Recent Car Repairs As A Member OF MBCA!

Actually, I saved more than \$300 in the past three months! The most recent repair replaced my glove compartment which, over a six month period, the leather slowly peeled away from the metal. Repair cost would have been \$900! But with my MBCA discount, I saved 15%!

My membership dues for this and the next two years were more than covered!!!

